



## **SCATEC-10 / 15**

### **Laser Copy Counter**

**FLDM 170G1011/S42**

**Scatec-10**

**FLDM 170C1011/S42**

**FLDM 170G1030/S42**

**Scatec-15**

**FLDM 170C1030/S42**

**FLDM 170x10/xxxxxx**

**customized**

User manual

Sensor Solutions

Motion Control

Vision Technologies

Process Instrumentation

## General notes

|                               |  |
|-------------------------------|--|
| <b>Rules for proper usage</b> | <p>This product represents a precision measuring device which has been designed for the detection of objects and parts. It generates and provides measured values issued as electrical signals for following systems.</p> <p>Unless this product has not been specifically marked it may not be used in hazardous areas.</p>   |
| <b>Set-up</b>                 | <p>Installation, mounting and adjustment of this product may only be executed by skilled employees.</p>  |
| <b>Installation</b>           | <p>Only mounting devices and accessories specifically provided for this product may be used for installation.</p> <p>Unused outputs may not be connected. Unused strands of hard-wired sensors must be isolated. Do not exceed the maximum permissible bending radius of the cable. Before connecting the product electrically the system must be powered down. Where screened cables are mandatory, they have to be used in order to assure EMI protection. When assembling connectors and screened cables at customer site the screen of the cable must be linked to the connector housing via a large contact area.</p> |

## Table of contents

- 1 **Safety information**
- 2 **Certifications**
- 3 **Introduction**
- 4 **Principle of operation**
- 5 **Part identification**
- 6 **Terms and definitions**
- 7 **Signal sequence**
- 8 **Installation**
- 9 **Setting the operational parameters**
- 10 **Display and user menu**
- 11 **Specifications**
- 12 **Accessories**
- 13 **Maintenance**
- 14 **Troubleshooting**
- 15 **Varying data for customized FLDM 170x10/xxxxxx**
- 16 **Supplements**

**customized FLDM 170x10/xxxxxx:**

**Data and information varying from the standard manual are listed in section 15 !**

## 1 Safety information

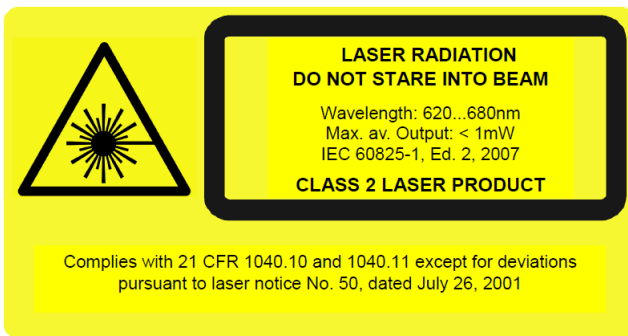

The laser diode installed in the **Scatec-10 / -15** emits visible red light. This laser belongs to the Class 2 laser standard specified by the IEC 60825-1 / 2007.

**Avoid looking directly into the beam for long periods. Brief irradiation of the eye (0.25 sec) that can occur during an accidental glance is not regarded to be dangerous.**

However, the laser should not be aimed deliberately at people. The laser beam should also be blocked at the end of its intended path.

## 2 Certifications

**Scatec-10 / -15** complies with the following safety standards:







Complies with 21CFR 1040.10 and 1040.11

### 3 Introduction

As a member of the **Scatec** family, the **Scatec-10 / -15** generally provides a means of detecting object edges. These sensors are best suited for non-contact counting of overlapping paper sheets and newspapers in the printing industry.

If an object with an edge facing the laser beam passes through the beam, the sensor reacts with an electrical output pulse. The user has several options to set the **Scatec-10 / -15** in such a way that certain edges are recognized as “false edges” and consequently do not initiate an output pulse. This option of suppressing certain edges allows the sensor to count newspapers to the highest degree of accuracy.

Within the **Scatec** family, the **Scatec-10** and the **Scatec-15** distinguish themselves by the following features:

| <b>Scatec-10</b> <i>FLDM 170x1011/S42</i>  | <b>Scatec-15</b> <i>FLDM 170x1030/S42</i>  |
|--|--|
|     |   |
| <ul style="list-style-type: none"> <li>• detects edges from a thickness of 0.1mm and thicker</li> </ul>  | <ul style="list-style-type: none"> <li>• detects edges from a thickness of 0.1mm and thicker</li> </ul>  |
| <ul style="list-style-type: none"> <li>• optimum working distance: 70 mm</li> </ul>  | <ul style="list-style-type: none"> <li>• optimum working distance: 100 mm</li> </ul>   |
| <ul style="list-style-type: none"> <li>• reliable gap detection via the built-in retro-reflective sensor (allowing consistent recognition of certain edges as “false edges”)</li> </ul>  |  |
| <ul style="list-style-type: none"> <li>• can be synchronized to the conveying speed (allowing for enhanced false pulse suppression)</li> </ul>   |  |
| <ul style="list-style-type: none"> <li>• high precision timing of pulse output</li> </ul>  |  |
| <ul style="list-style-type: none"> <li>• counting rate up to 1.5 million copies per hour</li> </ul>  |  |
| <ul style="list-style-type: none"> <li>• keypad and display for easy parameter setting</li> </ul>  |  |
| <ul style="list-style-type: none"> <li>• with interface for remote control and data collection (allowing analysis of product conditions while production is running. Indispensable for test and “trouble shooting”)</li> </ul> |  |
|  | <ul style="list-style-type: none"> <li>• with CAN-interface for remote control</li> </ul>  |

## 4 Principle of operation

Described simply, the **SCATEC-10/-15** consists of a laser light source and two photo detectors. The beam is aimed diagonally at the objects to be detected.

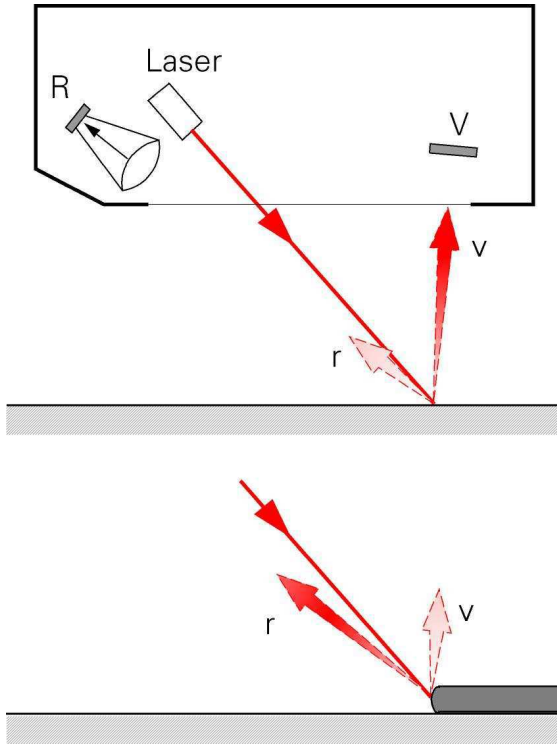

The photodetectors V and R detect laser light scattered by an object in the forward and backward direction, respectively. The ratio of light received by these two detectors differs widely depending on whether the beam strikes a flat surface or an edge. Compared to a flat surface, an edge obstructs the direct line of sight from the point of contact of the laser to the detector V and hence detector V receives less light. At the same time, an edge scatters more light toward detector R than a flat surface. Both effects cause the ratio of forward to backward scattered light  $v/r$  to become substantially smaller than with a flat surface. Therefore an edge is characterized by a value of this ratio below a specific threshold.

This principle of operation clearly demonstrates that:

- The orientation of the object to the beam is significant. An edge facing towards the beam creates a small ratio  $v/r$ , in contrast to an edge facing away from the beam.
- Edge detection is independent of the color, as only the ratio of the light intensities and not the absolute value is used for detection.

**5 Part identification**



Frontwindow Lower edge of sensor



Protection cap for Interface connector Main connector Interface connector

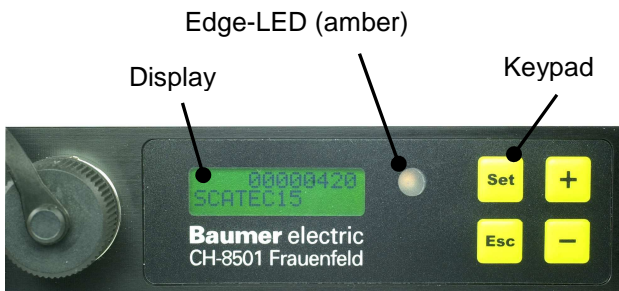

Edge-LED (amber) Display Keypad

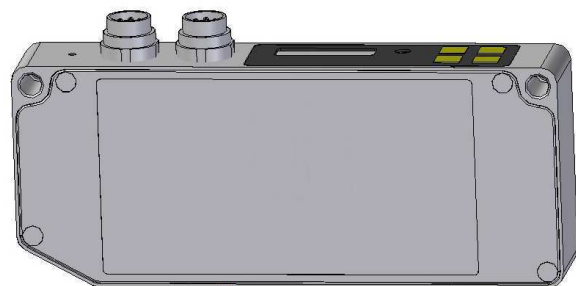

Laser beam Line focus (transverse to the Scatec)

## 6 Terms and definitions

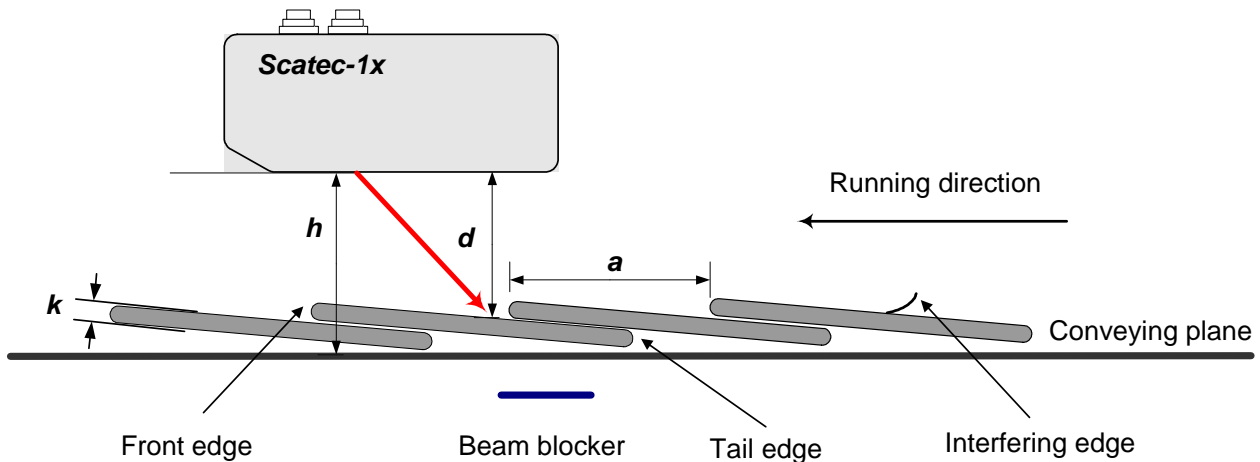

|                          |                 |   |
|--------------------------|-----------------|---|
| <b>Mounting height</b>   | <b><i>h</i></b> | Distance between the lower edge of the sensor and the conveying plane.  |
| <b>Working distance</b>  | <b><i>d</i></b> | Distance between the lower edge of the sensor and the plane where the edge lies on. Note that the working distance equals the mounting height only if the edge lies directly on the conveying plane.  |
| <b>Overlap</b>           | <b><i>a</i></b> | Interval between two successive edges, measured along the conveying plane.  |
| <b>Edge thickness</b>    | <b><i>k</i></b> | Thickness of the copy at the point where the edge is to be detected.  |
| <b>Front edge</b>        |                 | The edge of an object which faces the laser beam. In principle, edges facing the laser beam can be detected by the Scatec, independently of the running direction.  |
| <b>Tail edge</b>         |                 | The edge of an object which faces away from the laser beam. Edges facing away from the laser beam cannot be detected by the Scatec and do not initiate output pulses no matter the running direction is.  |
| <b>Running direction</b> |                 | For <b>Scatec-10 / -15</b> both running directions are allowed, with the front edge leading (a) or trailing (b). A front edge is detected independently of the running direction. However, for certain false pulse suppression modes to operate properly, the running direction must be set correctly.                |
| <b>Interfering edge</b>  |                 | Folds, fissures, creases, or other imperfections on a newspaper can form edges which will be detected by the Scatec but should not be counted. Such edges are termed "interfering edges" and cause so called "false pulses". Scatec-10 / -15 offers several possibilities to efficiently suppress these false pulses. |

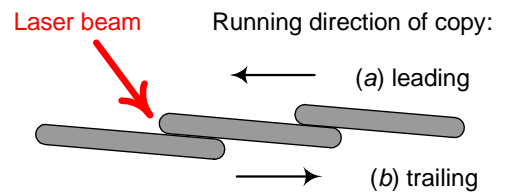
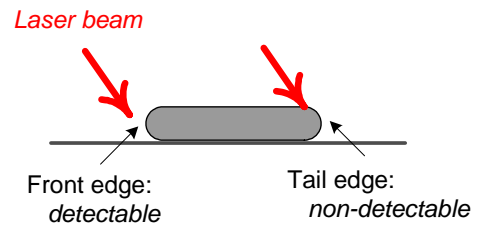



## 7 Signal sequence

The yellow edge indicator LED lights as long as the laser beam strikes an edge. The end of an edge (amber edge LED turns off) triggers the output pulse and the dead time. The dead time starts immediately with the trigger, while the delivery of the output pulse can be delayed (*pulse delay* adjustable by the customer). During the dead time, **SCATEC-10 /-15** is inactive, i.e. an edge ending during the dead time will not initiate an output pulse and is therefore suppressed. As a consequence output pulses are separated in time by at least the length of the dead time. Please note, the **Scatec-10 / -15** cannot deliver the next pulse before the preceding output pulse has elapsed. Therefore, an edge following after a time shorter than the output pulse length will be suppressed, even when the dead time is set to zero. Suppressed edges do not trigger a dead time.

The schematic below shows a pulse sequence where output pulses are delivered with no pulse delay and where some edges are suppressed because they occur during a dead time.

For in-depth explanations of pulse length and dead time, please refer to section 9.2 *Comments on the operational parameters*.

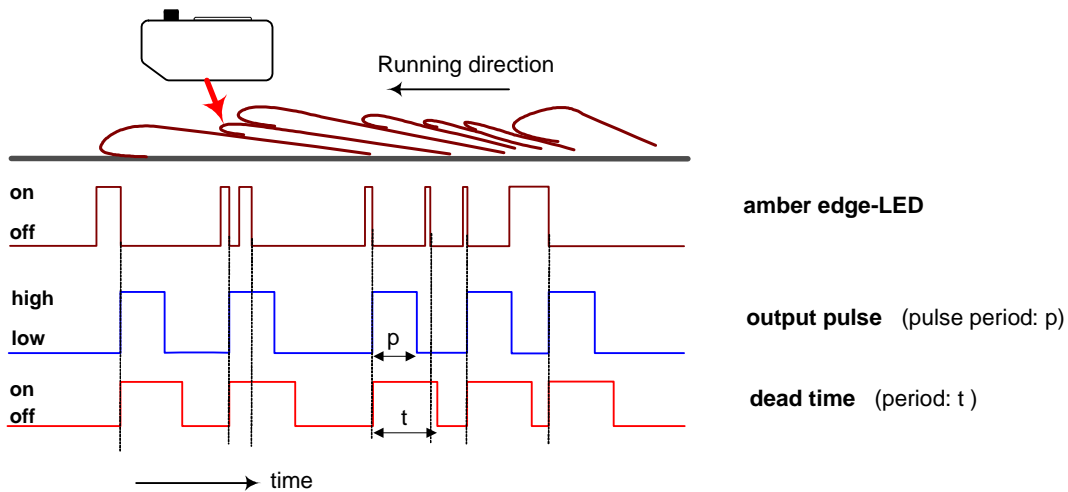

## 8 Installation

### 8.1 Electrical connection

Make the electrical connections as specified in Sections 11.2 *Electrical data*, 11.3 *Pin assignment*, and 11.6 *Wiring instructions*.

### 8.2 Mounting

- (1) **Scatec-10:** Mount the sensor at a mounting height  $h$  of 70 +/-2mm above or below the conveying plane with the front windows parallel (+/-3°) to the conveying plane.  
**Scatec-15:** Mount the sensor at a mounting height  $h$  of 100 +/-2mm above or below the conveying plane with the front windows parallel (+/-3°) to the conveying plane.
- (2) Adjust the sensor so that the laser beam is aimed towards the edges to be counted. Note that the laser beam is focused into a line which must be aligned in parallel to the edges to be detected!
- (3) Block the laser beam after the objects whenever possible.
- (4) Keep the window clean (no fingerprints).
- (5) A direct line of sight from the laser impact point to the entire front window must be ensured.

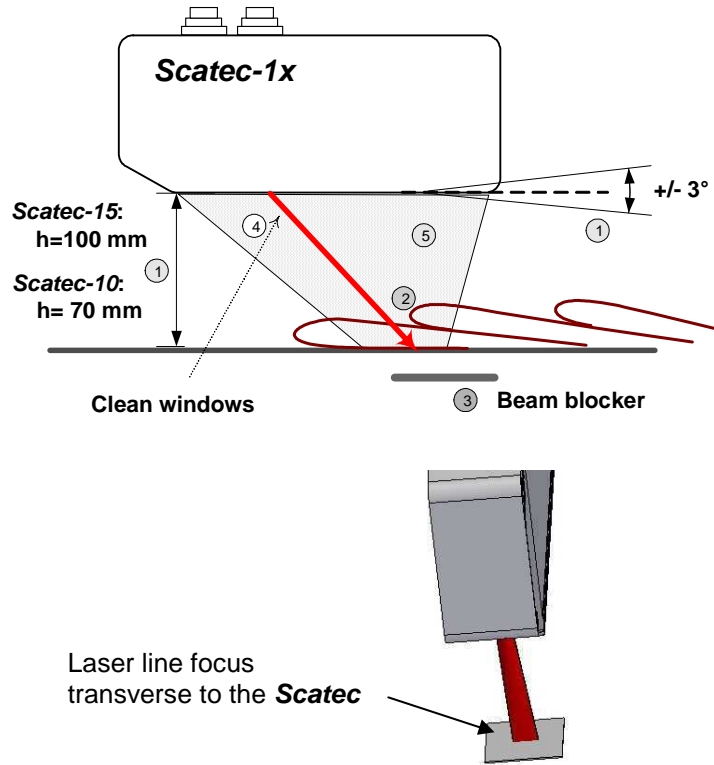

Comments:

|                      |   |
|----------------------|---|
| Mounting height: $h$ | <p><b>Scatec-10:</b> 70 +/-2mm above or below the conveyor belt<br/>         The resolution depends on the working distance. The highest resolution of 0.10 mm edge thickness is achieved at a working distance <math>d</math> of 68 – 72 mm. (See also section 11.8 <i>Application data</i>)</p> <p><b>Scatec-15:</b> 100 +/-2mm above or below the conveyor belt<br/>         The resolution depends on the working distance. The highest resolution of 0.15 mm edge thickness is achieved at a working distance <math>d</math> of 97 – 103 mm. (See also section 11.8 <i>Application data</i>)</p> |
| Tilting tolerance    | max. +/- 3°   |
| Overlap orientation  | <p>The edges to be counted must face toward the laser beam (front edges) whether they are leading or trailing.</p> <p>Make sure, that the laser line is parallel to the edge to be detected!</p>  |
| Front windows        | <p>The direct line of sight from the impact point of the laser to the entire front window must not be obstructed by any hardware for potential laser impact points in a distance range <math>d</math> of 0 – 150 mm (for <b>Scatec-10</b>) or 0 – 200 mm (for <b>Scatec-15</b>) If mounting brackets or other components are close, consult a technician from <i>Baumer Electric</i>.</p>   |

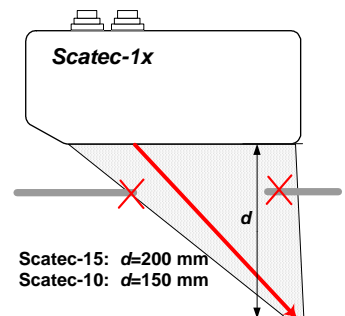

### 8.3 Beam blocker

Uncontrolled reflections of the laser beam can cause malfunctioning of the sensor or disturb people. Therefore, a beam blocker should be fitted whenever possible to block the beam when there is no target present. A beam blocker is a flat surface (at least 25mm x 25mm) made of any matte non-reflecting material. It is mounted parallel to the sensor at any convenient distance.

The amber edge-LED must not light while the laser beam hits a beam blocker!

### 8.4 Retro-reflective foil (Part # FTDF 025F025)

Gaps in a lap stream can be clearly detected by a **Scatec-10 / -15** if the retro-reflective foil (part number FTDF 025F025, shipped with the sensor) is mounted as a beam blocker. Certain false pulse suppression modes are based on a clear gap detection (for detailed explanation of these modes, refer to section 9.2 *Comments on the operational parameters.*)

#### Correct mounting of the retro-reflective foil:

- 1.) One side of the foil must be aligned parallel to the laser line.

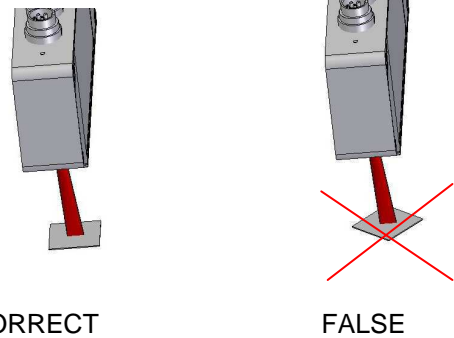

- 2.) **Scatec-10:**

Mounting distance: 70mm – 120mm away from the sensor's lower edge.

Tilt: 10° - 60° relative to the conveying plane

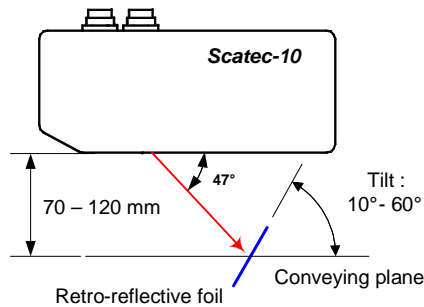

#### **Scatec-15:**

Mounting distance: 100mm – 150mm away from the sensor's lower edge.

Tilt: 0° - 45° relative to the conveying plane

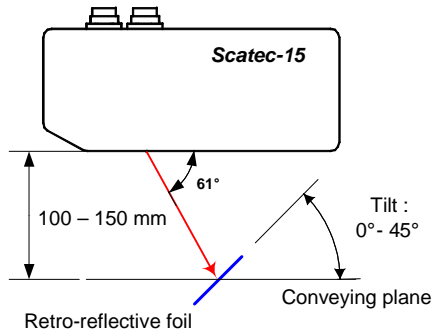

The amber edge-LED must light while the laser beam hits the retro-reflective foil!

## 8.5 Cleaning the front windows

Fingerprints, dust and other forms of dirt on the front window can impair the function of the sensor. It is normally sufficient to wipe the glass pane dry with a clean (!), soft cloth. Alcohol may be used for heavier soiling.

## 9 Setting the operational parameters

Various parameters allow the customer to fully adjust the **Scatec-10 / -15** to the specific demands of the actual application.

Parameter adjusting can be done in the following ways:

- via a PC, an interface, and the application software *ScaDiag* (consult the *ScaDiag*-manual)
- via the CAN-interface (only for **Scatec-15**) (consult the *Scatec* CAN-manual)
- via the sensor's key pad and display (described below)

### Parameter setting via the sensor's key pad and display

The setting of the operational parameters is done within a user's menu, using the four key pads [set], [Esc], [+], and [-].

The user's menu and the navigation are described in detail in section *10 Display and user menu* of this manual.

The **Scatec's** operational parameters are all grouped together in menu C.

This section of the manual describes in detail the characteristics of all the operational parameters. The procedure of how to enter a specific parameter value by means of the key-pad is described in section *10 Display and user menu* of this manual.

Note that usually the input has to be unlocked before any operational parameters can be changed.

The unlocking is done by setting setting parameter *[B1]* to *off* as follows:

- 1.) press [+] until *B Locks* is shown in the display
- 2.) press [set] : the display shows now *B1: 1 = on Input lock*
- 3.) press [set] : *1 = on* is blinking
- 4.) press [+] until *0 = off* is shown blinking in the display
- 5.) keep [set] pressed until blinking stops

Now the input is unlocked and the desired operational parameters can be set in menu C.

The input will be locked again if no key is pressed for 30 minutes.

## Flow chart for setting the operational parameters

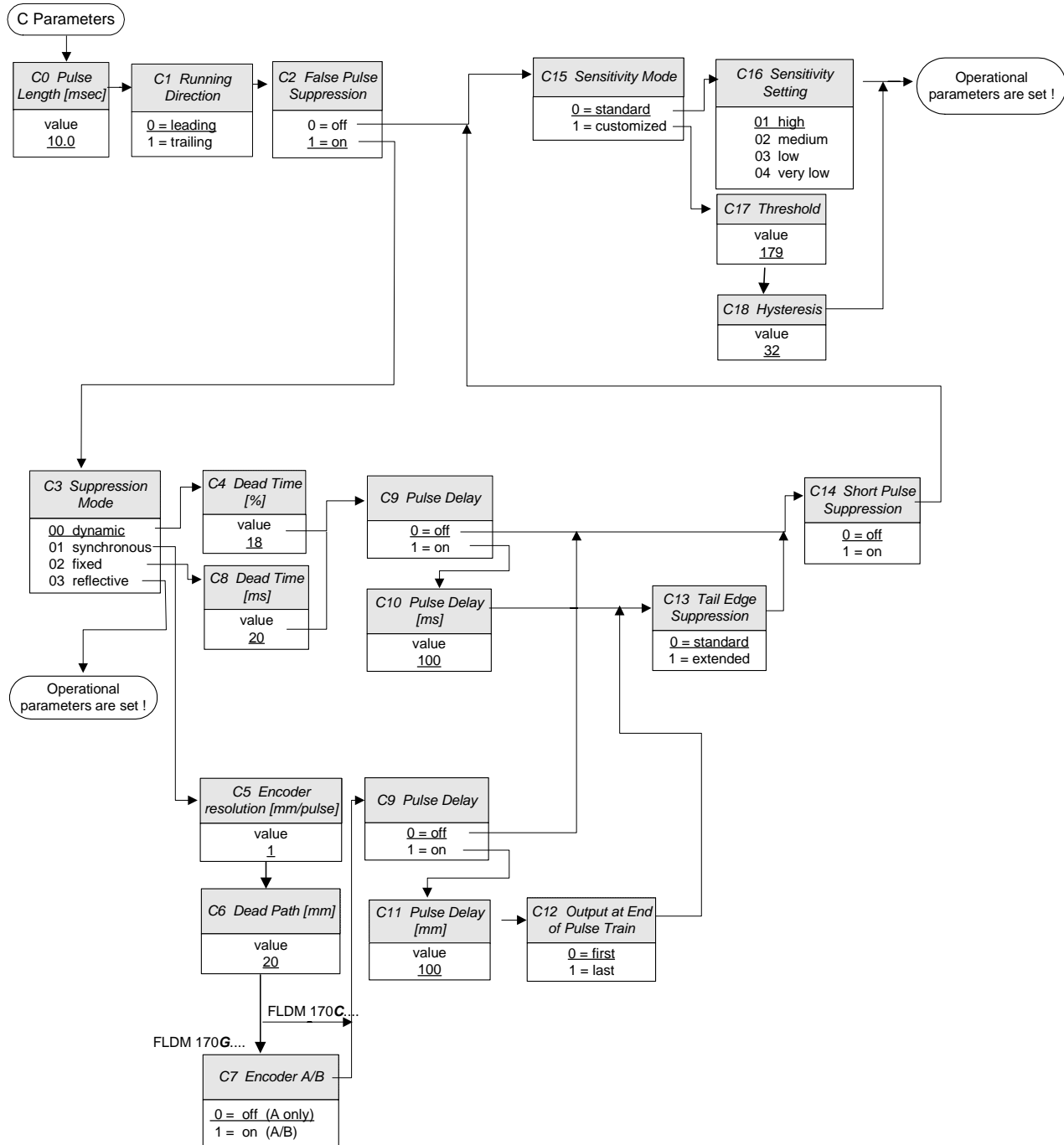

Default values are underlined. In most cases, the default setting will provide good results.  
 The factory preset default values can be reset anytime in submenu F4.  
 The names in the flow chart appear on the display as shown in square brackets in the next section.

### 9.1 Explanations on the operational parameters

Default values are either the underlined> input values or the input value in [square brackets].

**C0:** **Pulse Length** **[Pulse Length]**  
 Input values: 0.3ms – 99.9ms in increments of 0.1ms [10ms]  
 Function: to set the duration of an output pulse  
 Comments: On the one hand, the duration of an output pulse must be long enough so that the customer's control system can process it. On the other hand, the length of the output pulse limits the maximum counting rate. Because output pulses must not overlap, the interval between edges must be at least as long as one output pulse length. If the interval is shorter, then this edge will be suppressed meaning that the edge will not initiate an output pulse.  
 The following figure illustrates how every other edge is suppressed because of a too long of an output pulse length.

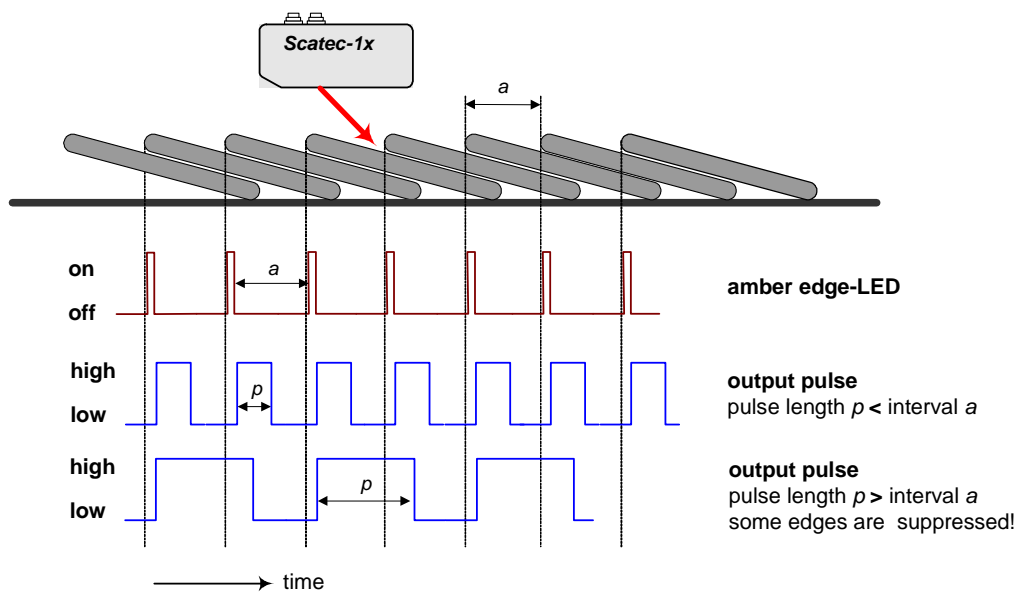

The maximum acceptable output pulse length for a given production rate can be read from the diagram below.

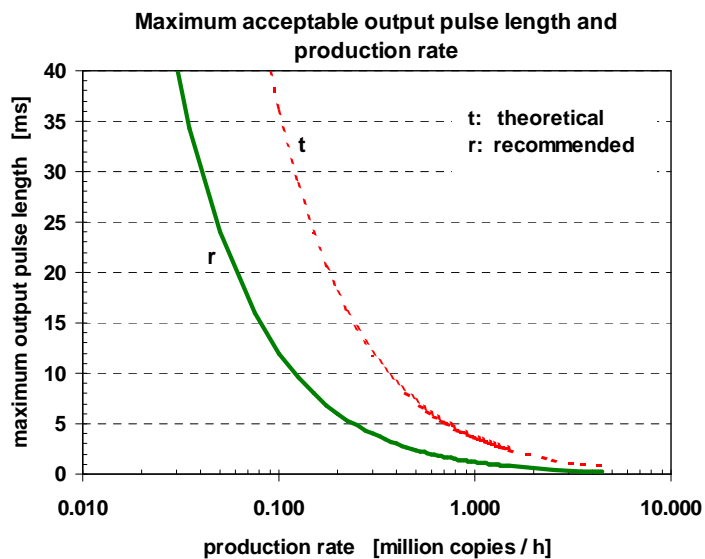



|               |   |                       |
|---------------|---|-----------------------|
| <b>C2:</b>    | <b>False pulse suppression</b>  | <b>[FP-Suppress.]</b> |
| Input values: | 0 = off      no false pulse suppression mode will be activated<br><u>1 = on</u> a false pulse suppression mode as defined in C3 will be activated |                       |
| Function:     | To specify whether or not any kind of false pulse suppression mode will be activated.   |                       |
| Comments:     | The specific mode of the false pulse suppression will be defined in menu C3.  |                       |

|               |  |                      |
|---------------|--|----------------------|
| <b>C3:</b>    | <b>Suppression mode</b>  | <b>[Suppr. Mode]</b> |
| Input values: | 00 = dyn      dynamic dead time<br><u>01 = sync</u> <u>synchronous dead time</u><br>02 = fixed      fixed dead time<br>03 = refl      retro-reflective foil only   |                      |
| Function:     | To select the type of dead time to be used or if the Scatec should react exclusively to the retro-reflective foil.   |                      |
| Comments:     | This menu is accessible only if menu C2 <i>false pulse suppression</i> was previously activated (C2 = 1)<br><u>General concept of dead time:</u> The time span during which the <b>Scatec</b> does not respond to any occurring edges (output set inactive) is named <i>dead time</i> . By starting a dead time by the end of an edge, a minimum interval between output pulses can be enforced because edges occurring during the dead time will be suppressed, i.e. do not initiate an output pulse nor trigger a dead time.<br>For example, setting a dead time allows counting the cut side of a newspaper, because the multiple edges formed by the individual sheets do not initiate multiple output pulses as long as they occur within the dead time triggered by the first edge as illustrated in the following sketch.<br>The dead time always starts with the end of an edge. |                      |

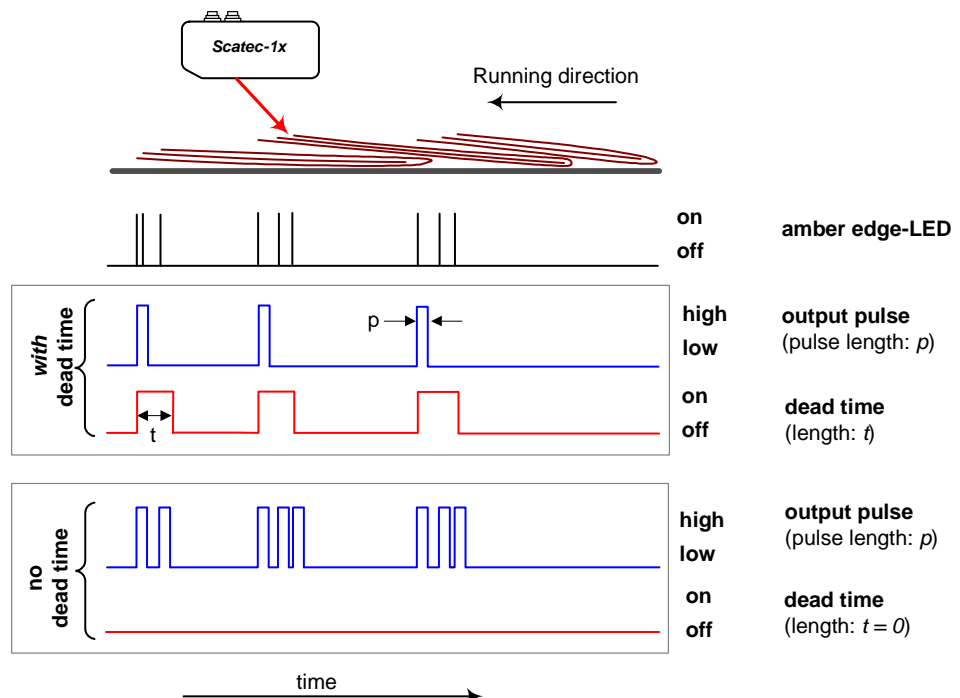

The amber edge-LED lights as long as the laser beam strikes an edge. Nevertheless, not every flash of the edge-LED is followed by an output pulse, because the edge might be suppressed!



There are three different types of dead time depending on how the dead time is specified.

Dynamic dead time (00 = dyn):

The length of the dead time corresponds to a certain percentage of the mean interval between copies.

If dynamic dead time is set as the suppression mode, then the percentage will be set subsequently in menu C4 (dead time %). The mean interval between copies is calculated continuously by the internal micro controller of the **Scatec-10 / -15** itself and is therefore simultaneously adapted to changes of the conveyor speed. This type of dead time is recommended as long as there is no possibility to synchronize the **Scatec**. With dynamic dead time as the suppression mode, occasionally, a counting error may occur if the lap-stream starts up very quickly from a standstill (particularly if the conveyor belt initially runs with no load and accelerates to maximum speed before copies appear on the conveyor belt) or when the conveyor belt stops abruptly. Do not use the dynamic dead time mode if the lap stream is highly irregular (i.e. highly varying intervals between copies). Taking single copies out of the otherwise regular lap stream does not cause any problems.

Synchronous dead time (01 = sync):

The output does not become active again until the conveyor has run a defined distance (regardless of the time it takes the conveyor to do this!).

**Scatec-10 / -15** can be connected to an encoder, which permits synchronization of the sensor to the conveyor speed. The big advantage of synchronization is that a false pulse suppression mode can be set which is completely independent of the conveyor speed, because now the output is set inactive not for a specific time but for a specific distance. In the synchronous dead time mode, the output is not set active again until the conveyor has run the dead path defined in menu C6. For example, the problem of multiple pulses generated by vibrations if the conveyor comes to a stand still with an edge exactly in the laser beam can be easily solved this way.

**Note: Whenever possible, use the synchronous dead time mode!**

If in menu C3 the synchronous dead time mode has been chosen, then subsequently in menu C5 the encoder resolution in millimeters per encoder pulse, in menu C6 the dead path, and in menu C7 the type of encoder (encoder with A/B-channel or A-channel only) has to be set. Based on the values for the encoder resolution and the dead path, the sensor will calculate internally for how many encoder pulses possible false pulses will be suppressed. Note, that with encoder type A/B chosen, the direction of transportation is taken into account. After an edge, the output is not set active again until the conveyor has run the dead path in the forward direction. If a **Scatec-10 / -15** with C7 set on (encoder with A/B-channel) does not give out any pulses although it detects edges (amber LED lights up), then the connections of the A/B channels have been mixed up. In his case the application software **ScaDiag** would display the warning "conveyor in reverse".

Fixed dead time (02 = fixed):

The length of the dead time is set to a fixed value in milliseconds.

Note: A fixed dead time imposes a limit to the maximum counting rate in the same way as the output pulse length. The same rule of thumb given in the description of C0 applies also to the fixed dead time, just substitute output pulse length by fixed dead time.

Retro-reflective foil only (03 = refl):

The **Scatec-10 / -15** reacts only to the retro-reflective foil and no longer to any edges.

Because the **Scatec-10 / -15** is equipped with a retro-reflective sensor, the sensor can unambiguously detect gaps in a lap stream, provided that there is a retro-reflecting tape (part number: FTDF 020F020) mounted as a beam blocker. This built-in retro-reflective sensor allows for a counting mode on its own. In the reflective mode, **Scatec- / -15** no longer detects edges, but reacts only to shadowing the retro-reflecting tape. As soon as the laser beam no longer strikes the retro-reflecting



*ScaDiag* would display the warning “conveyor in reverse”.

**C8:** **Dead time (msec)** **[Dead time ms]**  
 Input values: 0 to 999 in steps of 1 [20ms]  
 Function: to define the dead time as fixed value in milliseconds.  
 Comments: This parameter is accessible only if previously in menu *C3 fixed dead time* (C3 = 02) was activated.

**C9:** **Pulse delay** **[Pulse Delay]**  
 Input values: 0 = off output pulse issued immediately after end of the edge  
 1 = on output pulse issued with delay relative to end of the edge  
 Function: to define whether the output pulse is issued right after the end of an edge or with the delay as specified in menu C10 or C11.

Comments: A delayed output pulse is required in the following two applications:  
 1.) to trigger an action which is delayed relative to the end of the edge (for example: to trigger an ink jet printer for labeling newspapers)  
 2.) to suppress tail edges (for details see C13)  
 This parameter is accessible only if menu *C2 false pulse suppression* was previously activated (C2 = on). Depending on the mode of false pulse suppression chosen in menu C3, the output pulse delay will be specified in menu C10 in milliseconds or in menu C11 in millimeters.

The following sketch shows schematically the signal sequence of undelayed and delayed output pulse sequences. Note that both dead time and the output pulse are triggered with the end of an edge. However, the output pulse issue might be delayed while the dead time always starts right with the trigger.

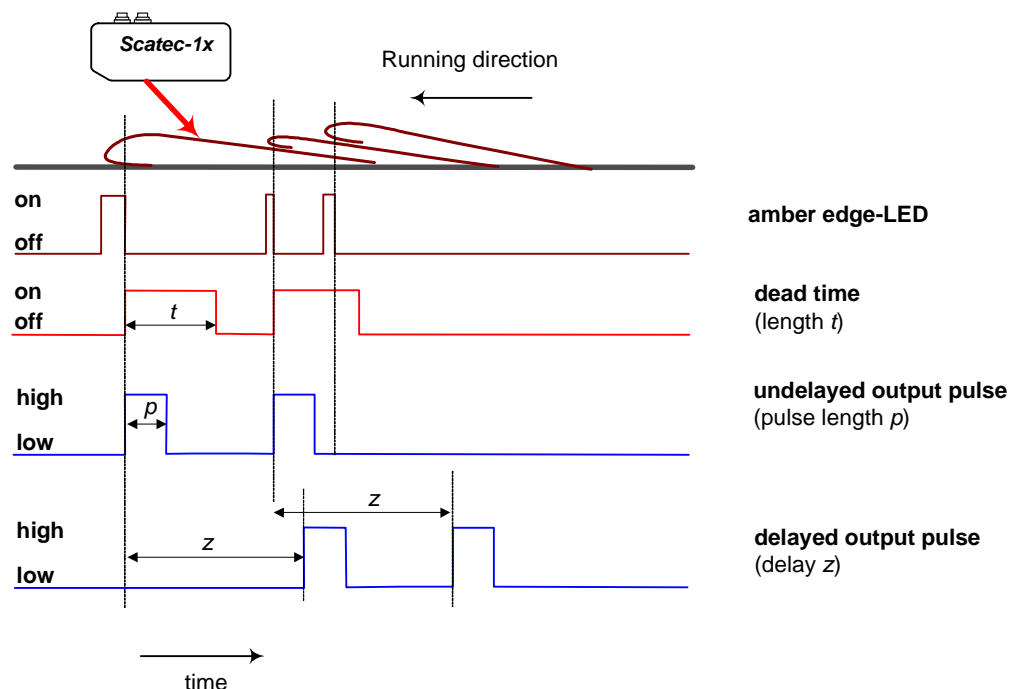

**C10:** **Pulse delay (msec)** **[Pulse Delay ms]**  
 Input values: 0 to 999 in steps of 1 [100ms]  
 Function: to define the value of the output pulse delay in milliseconds.

Comments: This parameter is accessible only if previously in menu *C9 delayed output pulse* (C9 = on) and in menu C3 either *dynamic dead time* (C3 = 00) or *fixed dead time* (C3 = 02) was chosen.

A maximum of 10 further edges may occur between the end of an edge and the delayed output pulse.

**C11: Pulse delay (mm) [Pulse Delay mm]**

Input values: 0 to 999 in steps of 1 [100mm]

Function: to define the value of the output pulse delay in millimeters.

Comments: This parameter is accessible only if menu *C9 delayed output pulse* (C9 = on) and menu C3 *synchronous dead time* (C3 = 01) were previously activated.

A maximum of 10 further edges may occur between the end of an edge and the delayed output pulse.

**C12: Output pulse triggered by last edge [Out@PlsTrain]**

Input values: 0 = first output pulse triggered by first edge of edge train  
 1 = last output pulse triggered by last edge of edge train

Function: to define whether the output pulse is triggered by the first or the last edge of a group of multiple edges occurring within one dead time.

Comments: This parameter is accessible only if menu *C9 delayed output pulse* (C9 = on) and menu C3 *synchronous dead time* (C3 = 01) were previously activated.

This parameter should be set to *on* if thick copies are processed and the **Scatec** is used to trigger another action (for example: labeling) where as little jitter as possible of the trigger point is required.

The following sketch shows the case where the fold of a thick newspaper breaks up into two edges because of a slight indentation. The second edge falls within the dead time triggered by the first edge. With parameter C12 set to *0=first*, the output pulse is triggered by the end of the first edge and the second edge is suppressed. If parameter C12 is set to *1=last*, the output pulse is initiated by the second edge while it is the first edge which is suppressed. This way, it has been achieved that although the fold is split up into two edges, it is still at the end of the fold where the output pulse is initiated as if the fold would form only one continuous edge.

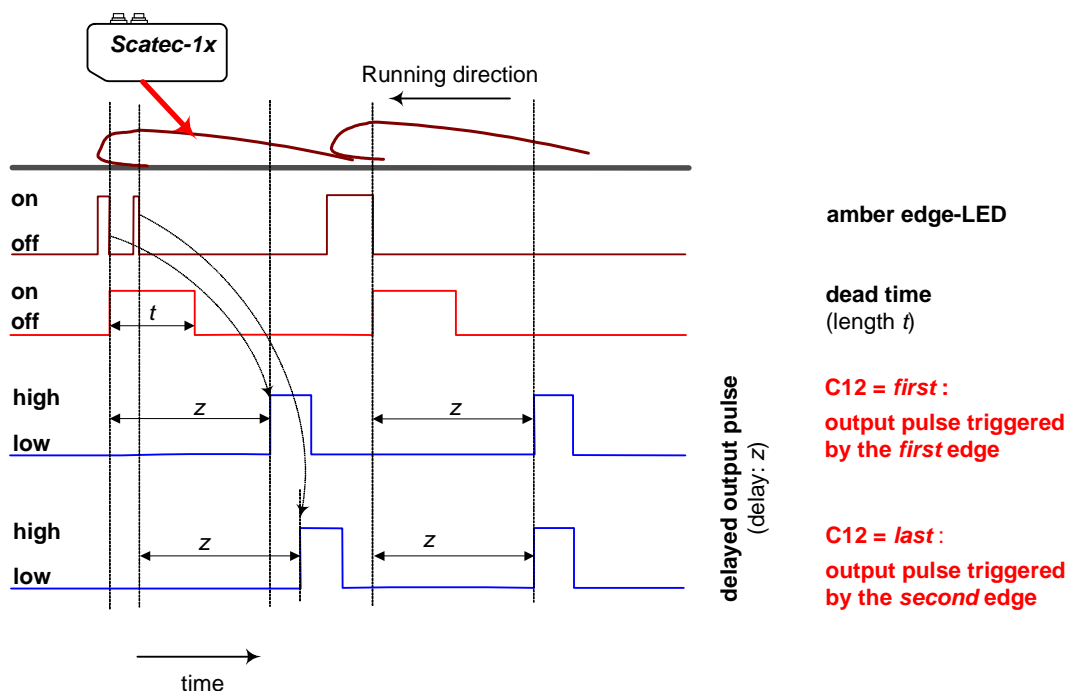

|               |   |                      |
|---------------|---|----------------------|
| <b>C13:</b>   | <b>Tail edge suppression</b>  | <b>[Tail Suppr.]</b> |
| Input values: | <u>0 = stand</u> edge suppressed if it is followed by a retro-reflective foil within the <i>dead time</i><br>1 = extnd edge suppressed if it is followed by a retro-reflective foil within the output pulse <i>delay time</i>   |                      |
| Function:     | to define whether the area checked for tail edges extends for a dead time (0 = stand) or for an output pulse delay time (1 = extnd).  |                      |
| Comments:     | This parameter is accessible only if menu <i>C9 delayed output pulse</i> (C9 = on) was previously activated.<br>Delaying the output pulse (C9 = on) also automatically activates a tail edge suppression. Parameter C13 decides which area is checked for tail edges. Tail edge suppression does not only suppress tail edges that are sticking up, but also edges generated by small paper scraps on the otherwise empty conveyor. |                      |

- Tail edge suppression works only with a mounted retro-reflective foil.
- Extended tail edge suppression works only with the front edges leading.

This configuration is sketched below.

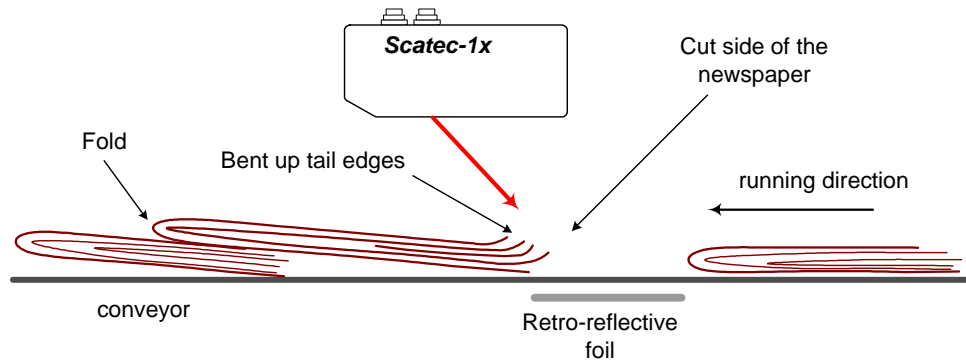

Usually newspapers are conveyed shingled and with the folded side facing the laser beam. As a consequence, the cut side of a copy is covered by the next copy and exposed to the laser beam only if there is a gap in the lap stream. The cut side of the newspaper is facing away from the laser beam, forming a tail edge and usually not detectable by the **Scatec**. However, some of these cut pages might be bent up. In the case of gaps in the lap stream, there is a risk of tail edges generating output pulses. Such bent up tail edges can not be suppressed by means of a dead time because the dead time would be triggered by the fold and had to practically cover the whole length of a copy. But that means a dead time bigger than the overlap leading to the unacceptable suppression of regular copies. However, if the pulse output is delayed and a retro-reflective foil mounted, then the **Scatec-10 / -15** can nevertheless be set in such a way that bent up tail edges are completely suppressed.

Therefore **Scatec-10 / -15** is able to suppress interfering tail edges provided:

- a retro-reflective foil mounted is mounted
- the output pulse is delayed (C9 = on)
- a suitable zone checked for tail edges is chosen (C13 = on or off)

A bent up tail edge is suppressed if it is followed by a gap within a specific time (or distance). This time or distance therefore defines a zone on the copy where edges will be suppressed as tail edges and can be set either equal to the dead time (dead path) or equal to the output pulse delay chosen earlier.

In order to set the tail edge suppression correctly, follow the subsequent flowchart and refer to the sketch below.

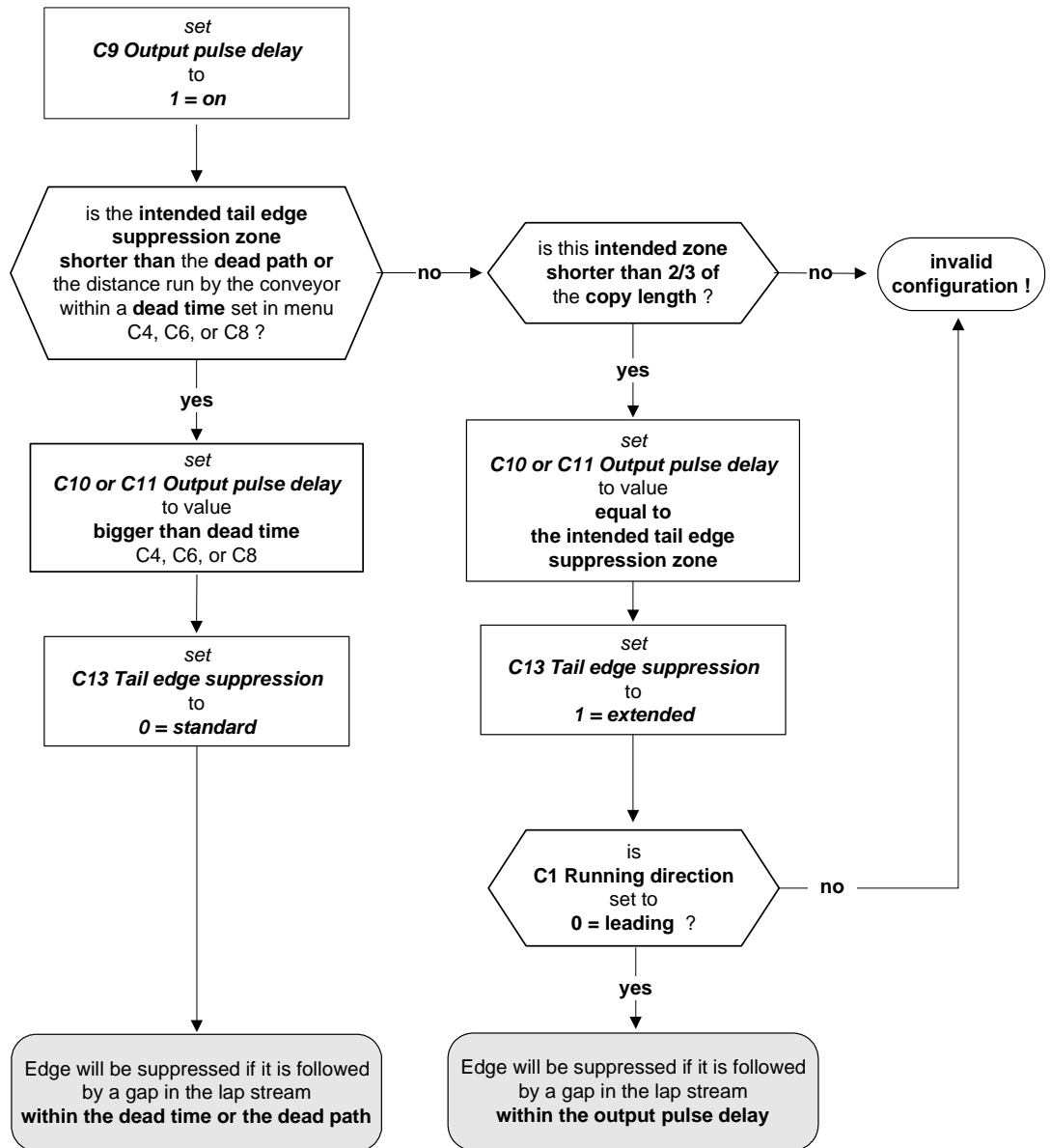
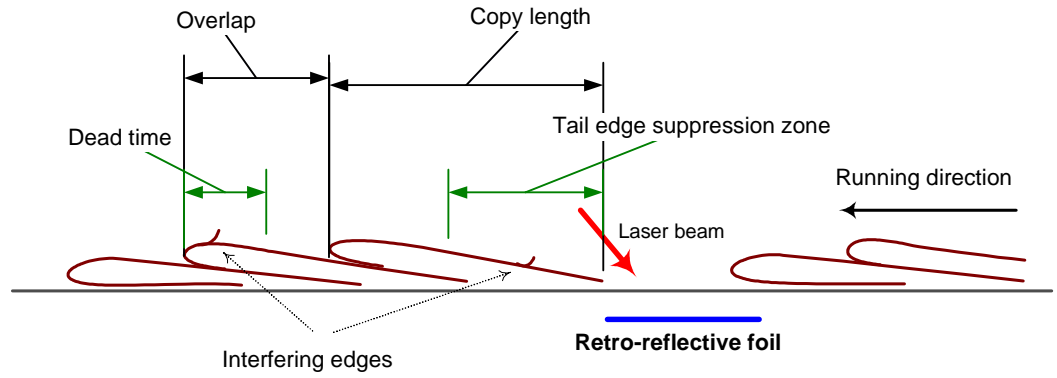

|  |   |                       |
|--|---|-----------------------|
| <b>C14:</b>  | <b>Short pulse suppression</b>  | <b>[ShrtP.Suppr.]</b> |
| Input values:  | <u>0 = off</u> short edges are not suppressed<br>1 = on          short pulses are suppressed  |                       |
| Function:  | to define whether short edges should be considered as interfering edges and be suppressed (1 = on) or not (0 =off). An edge is short if its duration is shorter than 25% of the mean edge duration.   |                       |
| Comments:  | <p>This parameter is accessible only if menu <i>C2 False pulse suppression</i> was previously activated (C2 = on).</p> <p>The duration of an edge can be a characteristic which clearly shows whether an edge should be suppressed or not. For example: thick newspapers will always generate long edges, so that a rather short edge within many long edges will most likely be an edge caused by some imperfections on the newspaper. With C14 <i>short pulse suppression</i> activated (C14 = on), edges with a duration of less than 25% of the mean edge duration will be suppressed. The mean edge duration is continuously calculated by the sensor and adapted to the conveyor speed.</p> |                       |
| Short pulse suppression works properly only if the running direction is leading! |   |                       |

|               |  |                       |
|---------------|--|-----------------------|
| <b>C15:</b>   | <b>Sensitivity mode</b>  | <b>[Sensvty Mode]</b> |
| Input values: | <u>0 = stand</u> standard<br>1 = custm      customized   |                       |
| Function:     | to define whether one of the standard sensitivity levels defined in C16 will be activated or if the sensitivity level will be set specifically by the customer in C17 and C18. |                       |
| Comments:     | A sensitivity level other than standard should be chosen only if the signals can be controlled by the application software <b>ScaDiag</b> .                                    |                       |

|               |   |                        |
|---------------|---|------------------------|
| <b>C16:</b>   | <b>Sensitivity setting</b>  | <b>[Sensvt Settng]</b> |
| Input values: | <u>01 = high</u> highest sensitivity<br>02 = mid        medium sensitivity<br>03 = low        low sensitivity<br>04 = v. low     very low sensitivity   |                        |
| Function:     | to define the actual sensitivity of the sensor.   |                        |
| Comments:     | <p>This parameter is accessible only if previously in menu <i>C15 standard sensitivity mode</i> was activated (C15 = 0).</p> <p>Paper sheets of at least 0.1 mm thick will be detected with the <b>Scatec-10</b> set to its highest sensitivity and mounted at a distance of 68mm to 72mm. The <b>Scatec-15</b> set to the highest sensitivity will detect sheets 0.15mm thick and larger at a distance of 97mm to 103mm. However, if set to the highest sensitivity, folds or wrinkles could cause interfering edges. If the edges to be detected are thick enough, than it might be an advantage to reduce the sensitivity to become less sensitive to interferences.</p> <p>Note: The sensitivity is dependant on the working distance. Please refer to the diagram in section <i>11.7 Application data</i>.</p> |                        |





## 10.2 Navigation

The graph below illustrates how to navigate and change a parameter value based on an example where the value of the pulse length is changed from 12.3ms to 45.6ms in submenu C0.

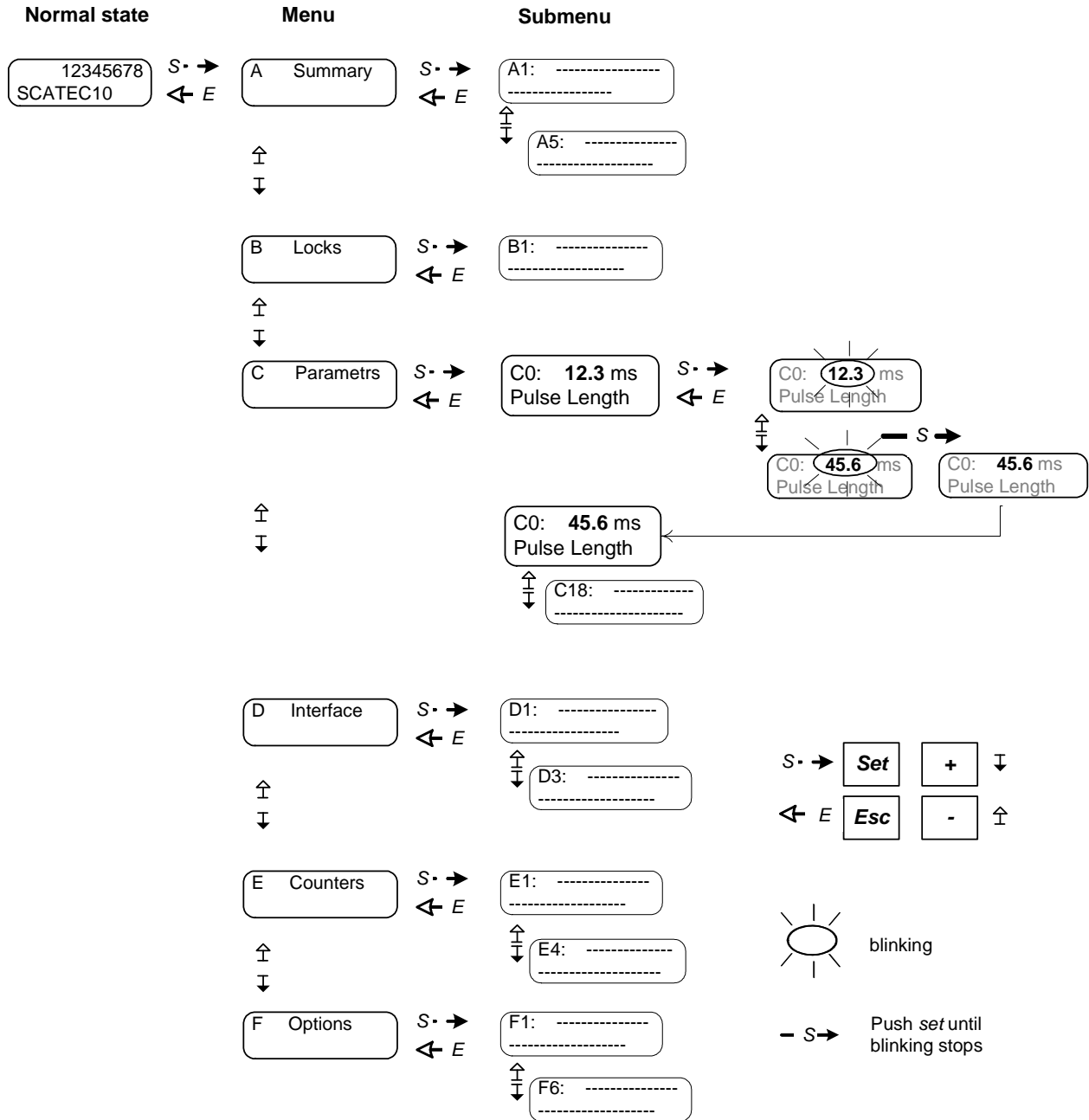

- Submenus not applicable in the present setting will be skipped on the display!
- Before parameters can be changed, the key pads have to be unlocked in menu B. With locked key pads, upon pressing *set*, the reminder *input locked* will be displayed.

## 10.3 Menus

### 10.3.1 Menu A: Summary

[Summary]

Menu A presents a summary of the current parameter setting.

**In menu A, no parameters can be set. It serves only as a display.**

Submenus that are not applicable in the current setting are not shown. For example: submenu A3 does not show up if a factory preset level was chosen for sensitivity.

If you have to contact a technician from *Baumer Electric* because of a problem with the **Scatec**, always have the parameter values on hand shown in this summary menu.

| Submenu                               | Values                                | Comments  |
|---------------------------------------|---------------------------------------|---|
| <b>A1:</b>                            | <b>abcd efg</b><br><b>hhhhh iiiii</b> | <b>a False pulse suppression mode</b><br>0 = dynamic dead time<br>1 = synchronous dead time<br>2 = fixed dead time<br>3 = retro-reflective foil only<br>* = not activated<br><br><b>b Pulse delay</b><br>0 = immediate pulse delivery<br>1 = delayed pulse delivery<br>* = not activated<br><br><b>c running direction</b><br>0 = leading<br>1 = trailing<br>* = not activated<br><br><b>d Output pulse triggered by last edge</b><br>0 = first edge triggers output pulse<br>1 = last edge triggers output pulse<br>* = not activated<br><br><b>e Short pulse suppression</b><br>0 = no short pulse suppression<br>1 = short pulses will be suppressed<br>* = not activated<br><br><b>f A/B Encoder</b><br>0 = only A-channel of the encoder is used<br>1 = A- and B-channel of the encoder are used<br>* = not activated<br><br><b>g Sensitivity level</b><br>1 = highest<br>2 = medium<br>3 = low<br>4 = very low<br>* = customized<br><br><b>h Dead time or path</b><br>xxxyy length of dead time or path with unit<br><br><b>i Output pulse delay</b><br>xxxyy delay of the output pulse with unit |
| <b>A2:</b><br><br><b>Length Resol</b> | <b>aa.a b.bb</b>                      | <b>Output pulse length and encoder resolution</b><br><b>aa.a</b> output pulse length in milliseconds<br><b>b.bb</b> encoder resolution in millimeters / pulse   |
| <b>A3:</b><br><br><b>Thresh/Hyst.</b> | <b>aaa bbb</b>                        | <b>Threshold and hysteresis</b><br><b>aaa</b> customized threshold<br><b>bbb</b> customized hysteresis  |

|                                   |          |  |
|-----------------------------------|----------|--|
| <b>A4:</b><br><b>SW-Revision</b>  | aaaaaaa  | <b>Version of the Scatec operation software</b><br>version consists of 6 numbers plus one letter (example: 060421a)  |
| <b>A5:</b><br><b>Type</b>         | FLDM170  | <b>Scatec type</b>   |
| <b>A6:</b><br><b>Remote Param</b> | abcd CAN | <b>CAN Interface</b><br><b>a CAN mode</b><br>0 = value of CAN Object 2000 is 3<br>1 = value of CAN Object 2000 is not 3<br><b>b Compensation of synchronization point</b><br>(CAN-object2300, subindex 02, bit 0)<br>0 = off<br>1 = on<br><b>c Inserting missing counts</b><br>(CAN-object2300, subindex 02, bit 1)<br>0 = off<br>1 = on<br><b>d Automatic sensitivity adjustment</b><br>(CAN-object2300, subindex 02, bit 2)<br>0 = off<br>1 = on |

### 10.3.2 Menu B: Locks

[Locks]

To protect the sensor against accidental or unauthorized manipulation of the parameter settings, the input can be blocked in this menu. With a locked sensor, navigation is still possible.

There are two security levels. By default, the sensor is on the lower security level where unlocking is done by setting parameter [B1] to *off*.

**The sensor will be locked again if no key is pressed for 30 minutes**

On a higher security level, the sensor can be protected against unauthorized tampering by requiring the user to enter an ID code before the sensor will be unlocked. This higher security level can be activated by setting parameter [F5], Lock-ID-code, to *on*.

**The ID-code (which is asked for) is 55 and cannot be changed.**

| Submenu                          | Values            | Comments   |
|----------------------------------|-------------------|--|
| <b>B1:</b><br><b>Input Lock</b>  | 0 = off<br>1 = on | sensor unlocked<br>sensor locked   |
| <b>B2:</b><br><b>Unlock Code</b> | xxx               | ID-code is 55 and can not be changed.<br>(the ID-code-locking is activated in submenu F5). |

**10.3.3 Menu C: Parameters**
**[Parameters]**

Operational parameters are set in menu C. A detailed description of these parameters is given in section 9 *Setting the operational parameters*.

- Submenus not applicable in the present setting will be skipped in the display!
- With the sensor locked, no parameters can be changed while navigation is still possible. The sensor can be unlocked in menu B. When trying to change a parameter of a locked Scatec, the message “input locked” will show up as reminder.
- The sensor will be locked again if no key is pressed for 30 minutes

| Submenu                     | values  | Comments   |
|-----------------------------|---|--|
| <b>C0:<br/>Pulse Length</b> | xx.x ms   | <b>Output pulse length in ms</b><br>value of output pulse length in milliseconds   |
| <b>C1:<br/>RunDirection</b> | 0 = lead<br>1 = trail                             | <b>Running direction of the copies</b><br>leading<br>trailing  |
| <b>C2:<br/>Fp-Suppress</b>  | 0 = off<br>1 = on                                 | <b>False pulse suppression</b><br>no false pulse suppression mode will be activated<br>a false pulse suppression mode as defined in [C3] will be activated |
| <b>C3:<br/>Suppr.Mode</b>   | 00 = dyn<br>01 = sync<br>02 = fixed<br>03 = reflx | <b>False pulse suppression mode</b><br>dynamic<br>synchronous<br>fixed<br>retro-reflective foil only   |
| <b>C4:<br/>Dead Time %</b>  | xxx   | <b>Dead time in percentage</b><br>value of dynamic dead time in percentage of the mean interval between copies   |
| <b>C5:<br/>Encodr Resol</b> | x.xx mm   | <b>Encoder resolution in mm/pulse</b><br>value of encoder resolution in millimeters per encoder pulse  |
| <b>C6:<br/>Dead Path mm</b> | xxx mm  | <b>Dead path in mm</b><br>value of synchronized dead path mm   |
| <b>C7:<br/>Encoder A/B</b>  | 0 = off<br>1 = on                                 | <b>Encoder A/B</b><br>only A-channel of encoder is used<br>A- and B-channels of encoder are used   |
| <b>C8:<br/>Dead Time ms</b> | xxx ms  | <b>Dead time in ms</b><br>value of fixed dead time in milliseconds   |
| <b>C9:<br/>Pulse Delay</b>  | 0 = off<br>1 = on                                 | <b>Output pulse delay</b><br>output pulse issued immediately after end of the edge<br>output pulse issued with delay relative to end of the edge           |

|                              |   |  |
|------------------------------|---|--|
| <b>C10:<br/>Pulse Delay</b>  | xxx ms  | <b>Output pulse delay in ms</b><br>value of output pulse delay in milliseconds   |
| <b>C11:<br/>Pulse Delay</b>  | xxx mm  | <b>Output pulse delay in mm</b><br>value of output pulse delay in millimeters  |
| <b>C12:<br/>Out@PlsTrain</b> | 0 = first<br>1 = last                           | <b>Output pulse triggered by last edge</b><br>output pulse triggered by first edge of edge train<br>output pulse triggered by last edge of edge train  |
| <b>C13:<br/>Tail.Suppr.</b>  | 0 = stand<br>1 = extnd                          | <b>Tail edge suppression</b><br>edge suppressed if it is followed by a retro-reflective foil within the <i>dead time</i><br>edge suppressed if it is followed by a retro-reflective foil within the output pulse <i>delay time</i> |
| <b>C14:<br/>ShrtP.Suppr.</b> | 0 = off<br>1 = on                               | <b>Short pulse suppression</b><br>short edges will not be suppressed<br>short edges will be suppressed   |
| <b>C15:<br/>Sensvty Mode</b> | 0 = stand<br>1 = custm                          | <b>Sensitivity mode</b><br>standard sensitivity levels as defined in C16 will be activated<br>sensitivity as defined by customer in C17 and in C18 will be activated   |
| <b>C16:<br/>Sensvt Level</b> | 01 = high<br>02 = mid<br>03 = low<br>04 = v.low | <b>Sensitivity level</b><br>highest<br>medium<br>low<br>very low   |
| <b>C17:<br/>Threshold</b>    | xxx   | <b>Threshold</b>   |
| <b>C18:<br/>Hysteresis</b>   | xxx   | <b>Hysteresis</b><br>value of the hysteresis   |

**10.3.4 Menu D: Interface**
**[Interface]**

Parameters concerning the CAN-interface are set in menu C

Only Scatec-15 is equipped with a CAN interface.

| Submenu                    | Values   | Comments   |
|----------------------------|--|--|
| <b>D2:<br/>CAN Baud</b>    | 00 = 10 kBaud<br>01 = 20 kBaud<br>02 = 50 kBaud<br>03 = 100 kBaud<br>04 = 125 kBaud<br>05 = 250 kBaud<br>06 = 500 kBaud<br>07 = 800 kBaud<br>08 = 1000 kBaud | <b>CAN Baudrate</b><br><br>default value: 01 = 20 kBaud                                |
| <b>D3:<br/>CAN-Node-Id</b> | xxx  | <b>CAN-Node-Id</b><br>Node-ID must be a number between 1 and 127<br>(default value: 1) |

**10.3.5 Menu E: Counter**
**[Counters]**

In menu E, several counters can be read and reset.

| Submenu                     | Values            | Comments  |
|-----------------------------|-------------------|---|
| <b>E1:<br/>Copy Counter</b> | xxxxxxxx          | <b>Copy counter</b><br>Total number of counted edges or output pulses since last reset  |
| <b>E2:<br/>marg.counted</b> | xxxxxxxx          | <b>Marginally counted edges</b><br>Total number of edges which were counted but which dropped only marginally below threshold                             |
| <b>E3:<br/>marg. missed</b> | xxxxxxxx          | <b>Marginally missed edges</b><br>Total number of edges which were not counted because they marginally missed the threshold                               |
| <b>E4:<br/>Reset Cntrs.</b> | 0 = no<br>1 = yes | <b>Counter reset</b><br>counters will not be reset<br>counters will be reset to 0<br><br>The counters are automatically reset upon power up of the sensor |

**10.3.6 Menu F: Options**
**[Options]**

In menu F, the operational parameters (set in menu C) can be reset to the factory preset default values.

Such a reset does not affect any CAN parameters set in menu D.

In addition, this menu contains a security code that can be activated to lock the key pad securely.

| Submenu                           | Values            | Comments  |
|-----------------------------------|-------------------|---|
| <b>F4:</b><br><b>SensrDefault</b> | 0 = no<br>1 = yes | <b>Reset of the operational parameters</b><br>No reset is initiated<br>The factory preset default operational parameter values are loaded |
| <b>F5:</b><br><b>Lock-ID-Code</b> | 0 = no<br>1 = yes | <b>Sensor locking by ID-Code</b><br>sensor not locked by ID-Code<br>sensor locked by ID-Code  |
| <b>F6:</b><br><b>Code Confirm</b> | xxx               | <b>ID-Code confirmation</b><br>The code is 55 and can not be changed.   |

## 11 Specifications

### 11.1 Mechanical and thermal data

|                           |                               |
|---------------------------|-------------------------------|
| Sensor size               | 170 x 70 x 30 mm              |
| Housing material          | zinc die-cast                 |
| Front windows             | glass                         |
| Weight                    | approximately 700 g           |
| Protection class          | IP 54                         |
| Working temperature range | 0°C to +50°C (non-condensing) |
| Storage temperature       | -20°C to +60°C                |

#### Scatec-10:

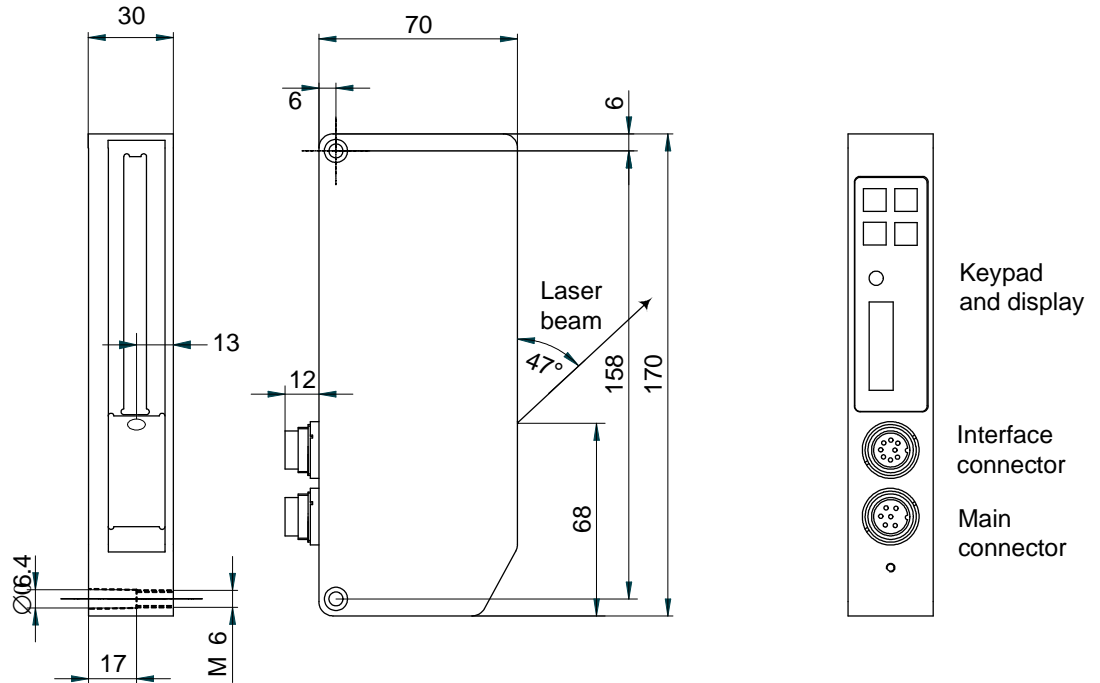

#### Scatec-15:

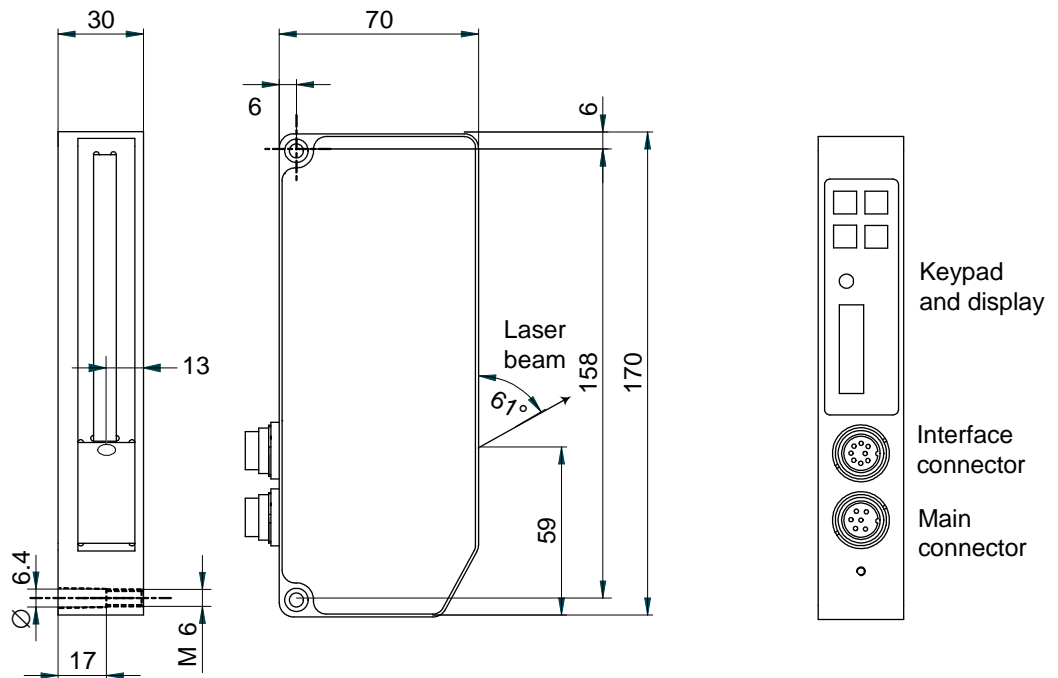



## 11.2 Electrical data

|                           |                                |
|---------------------------|--------------------------------|
| Operating voltage $V_S$   |                                |
| Limits:                   | +10 VDC to +30VDC              |
| Reverse-protected         | yes                            |
| Ripple $V_S$              | 10% within the limits of $V_S$ |
| Power consumption         | < 2 W                          |
| Current consumption       |                                |
| Average:                  | < 170 mA                       |
| Peak (after switching on) | < 180 mA                       |
| Connectors                |                                |
| Main connector            | DIN 45322, 6-pole, male        |
| Interface connector       | DIN 45326, 8-pole, male        |
| Output circuit            |                                |
| FLDM 170G...              | push-pull                      |
| normal state              | low                            |
| FLDM 170C...              | opto-isolated                  |
| switchable voltage        | maximum 40 V                   |
| Load resistance           | maximum 50 kOhm                |
| Current load:             | max. 100 mA                    |
| Short-circuit protected   | yes                            |
| Output pulse length       | selectable 0.3 ... 100ms       |

## 11.3 Pin assignment (looking at connector on Scatec)

**Main connector**      DIN 45322, 6 pole, male

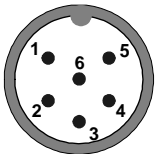

| Pin | Assignment                 |                |
|-----|----------------------------|----------------|
| 1   | output signal +Vout        |                |
| 2   | encoder input B            | (FLDM 170G...) |
|     | output signal -Vout        | (FLDM 170C...) |
| 3   | operating voltage +Vs      |                |
| 4   | encoder GND                |                |
| 5   | encoder input A            |                |
| 6   | operating voltage GND (0V) |                |

**Interface connector**      DIN 45326, 8 pole, male

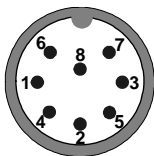

| Pin | Assignment          |
|-----|---------------------|
| 1   | CAN_H               |
| 2   | not connected       |
| 3   | serial TxD (sensor) |
| 4   | CAN_L               |
| 5   | serial RxD (sensor) |
| 6   | CAN_GND             |
| 7   | serial GND          |
| 8   | GND                 |

## 11.4 Output connection

### 11.4.1 Push-pull output (FLDM 170G...)

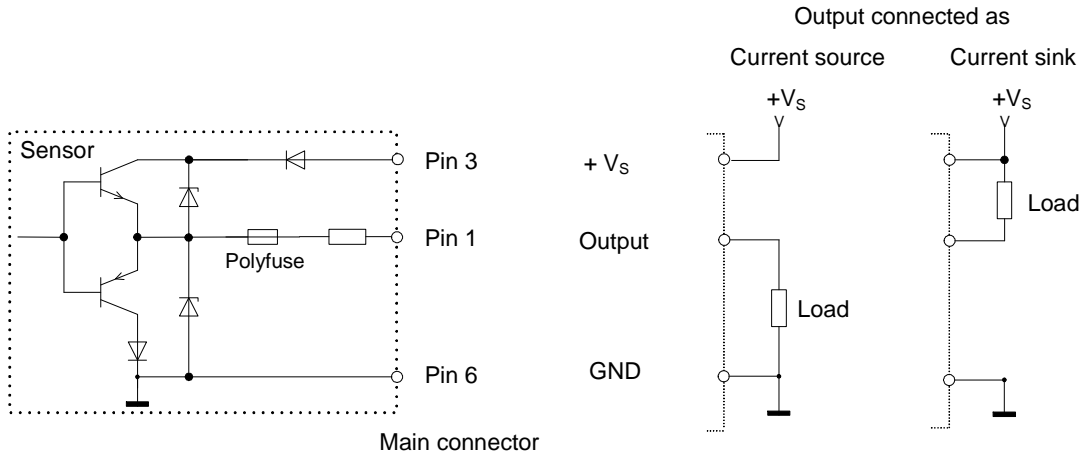

$+V_S$  Operating voltage (+10VDC ... +30VDC)

$V_{out}$  Output signal

$I_{Load}$  maximum 100 mA

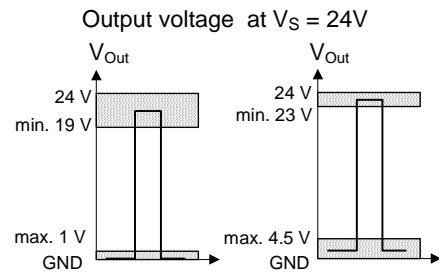

### 11.4.2 Opto-isolated output (FLDM 170C...)

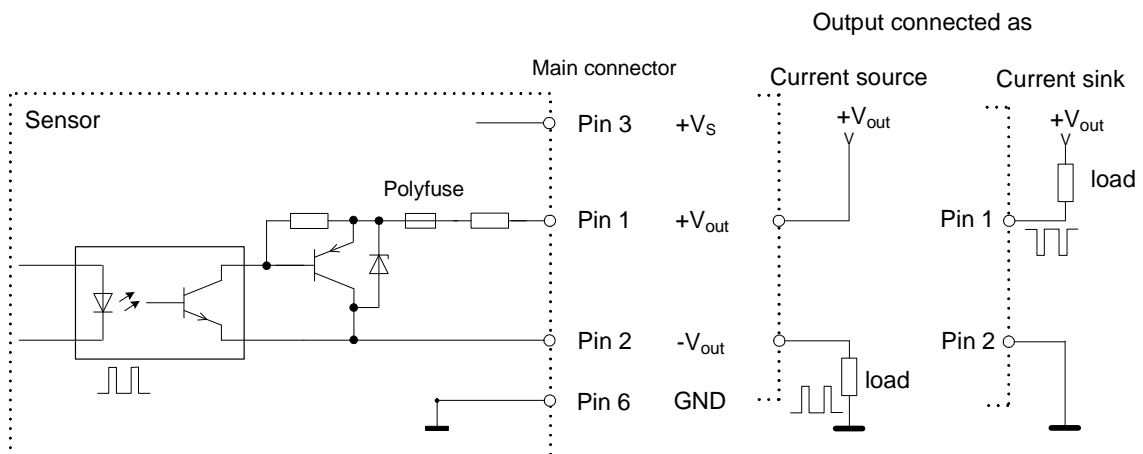

$+V_S$  Operating voltage (+10VDC ... +30VDC)

$+V_{out}$  Output signal +

$-V_{out}$  Output signal -

GND 0 V

$R_{Load}$  maximum 50 kOhm

$I_{Load}$  maximum 100 mA

Switchable voltage ( $+V_{out}$  minus  $-V_{out}$ ) maximum 40 V

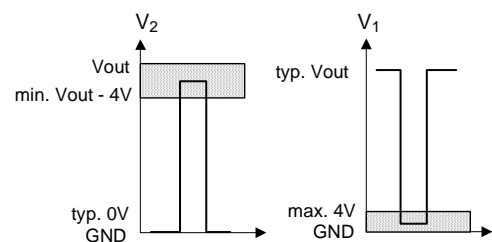

## 11.5 Synchronization input

- opto-isolated input
  - input signals between 5V and 30 V
  - for NPN- or PNP-open collector, push-pull, or TTL encoder output
  - Scatec FLDM 170G..... (push-pull output) accepts an A/B-channel encoder
  - Scatec FLDM 170C..... (opto-isolated output) accepts an A-channel encoder only.
- 
- synchronization input signal levels
 

|                       |                    |
|-----------------------|--------------------|
| logical <i>high</i> : | > 3.8 V (> 2.2 mA) |
| logical <i>low</i> :  | < 1.8 V (< 0.7 mA) |
  - frequency
 

|             |
|-------------|
| max. 50 kHz |
|-------------|
  - reverse polarity:
 

|           |
|-----------|
| protected |
|-----------|

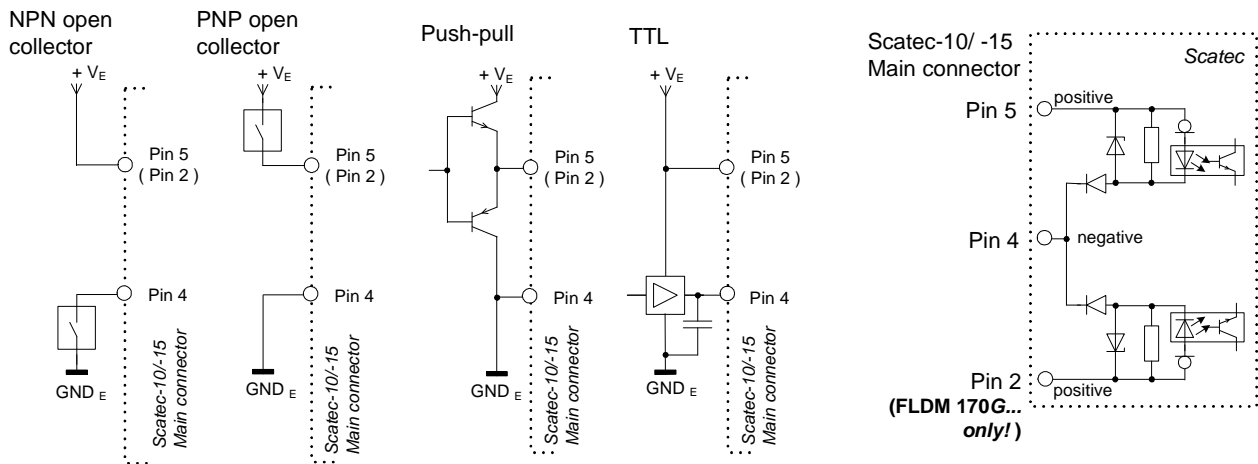

+ V<sub>E</sub> : Output voltage of the encoder  
 GND<sub>E</sub> : GND of the encoder

## 11.6 Wiring instructions

In order to achieve optimum protection of the **Scatec** against electromagnetic interference

- use shielded cables
- keep the ground impedance sufficiently low

We suggest the following two grounding schemes:

### Version 1

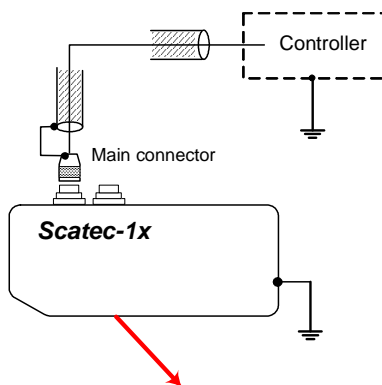

- **Scatec** housing is grounded (use teeth lock washers when mounting the **Scatec**).
- Cable shield **not** grounded at the controller end.
- Cable shield properly attached to the connector plugging into the **Scatec**.

## Version 2

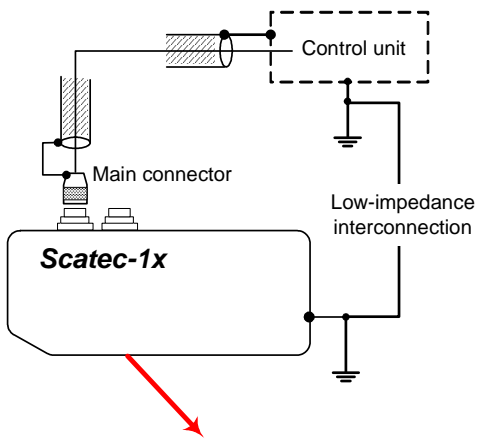

- **Scatec** housing is grounded (use teeth lock washers when mounting the **Scatec**)
- Cable shield properly grounded at the controller end
- Cable shield properly attached to the connector plugging into the **Scatec**.
- Keep the impedance of the interconnection between the control unit's ground and the Scatec ground sufficiently low.

## 11.7 Optical data

### Laser

|                 |                               |
|-----------------|-------------------------------|
| Wavelength      | 650 nm - 680 nm (visible red) |
| Pulse frequency | 50 kHz                        |
| Duty cycle      | 50%                           |
| Average power   | < 1.0 mW                      |
| Laser class     | 2 (to IEC 60825-1 / 2007)     |

### Beam dimensions

|                   |                       |                       |
|-------------------|-----------------------|-----------------------|
| at emission point | about 2.5 x 4.0 mm    |                       |
| <b>Scatec-10:</b> | 70 mm beneath sensor  | Line focus, 6 mm long |
| <b>Scatec-15:</b> | 100 mm beneath sensor | Line focus, 8 mm long |

### Focus position

|                   |                       |
|-------------------|-----------------------|
| <b>Scatec-10:</b> | 70 mm beneath sensor  |
| <b>Scatec-15:</b> | 100 mm beneath sensor |

### Optical receiver

equipped with near infrared suppression and daylight suppression filter

## 11.8 Application data

### Measuring range

|                   |                            |
|-------------------|----------------------------|
| <b>Scatec-10:</b> | 0 to 90 mm beneath sensor  |
| <b>Scatec-15:</b> | 0 to 120 mm beneath sensor |

### Mounting height

|                   |        |
|-------------------|--------|
| <b>Scatec-10:</b> | 70 mm  |
| <b>Scatec-15:</b> | 100 mm |

### Object speed

2 m/s maximum (5 m/s maximum for thicker edges)

### Minimum object spacing

10 mm @  $v = 1$  m/s and output pulse length 10 ms, or proportional to the speed and output pulse length

### Counting rate

1.5 million maximum copies/h (@ 2 ms output pulse length and 0 ms dead time)

### Product orientation

Folded or cut edge facing laser beam

### Output pulse length

0.2 ... 100 ms adjustable

## Sensitivity

**Scatec-10:**

edge thickness 0.1 mm and greater  
 highest sensitivity 68 ... 72 mm beneath sensor  
 product speed for edge thickness 0.10 mm ... 0.2 mm slower than 1 m/s

**Scatec-15:**

edge thickness 0.15 mm and greater  
 highest sensitivity 97 ... 103 mm beneath sensor  
 product speed for edge thickness 0.15 mm ... 0.2 mm slower than 1 m/s

The sensitivity is dependant on distance and product speed.  
 Typical sensitivity characteristic see diagram below.

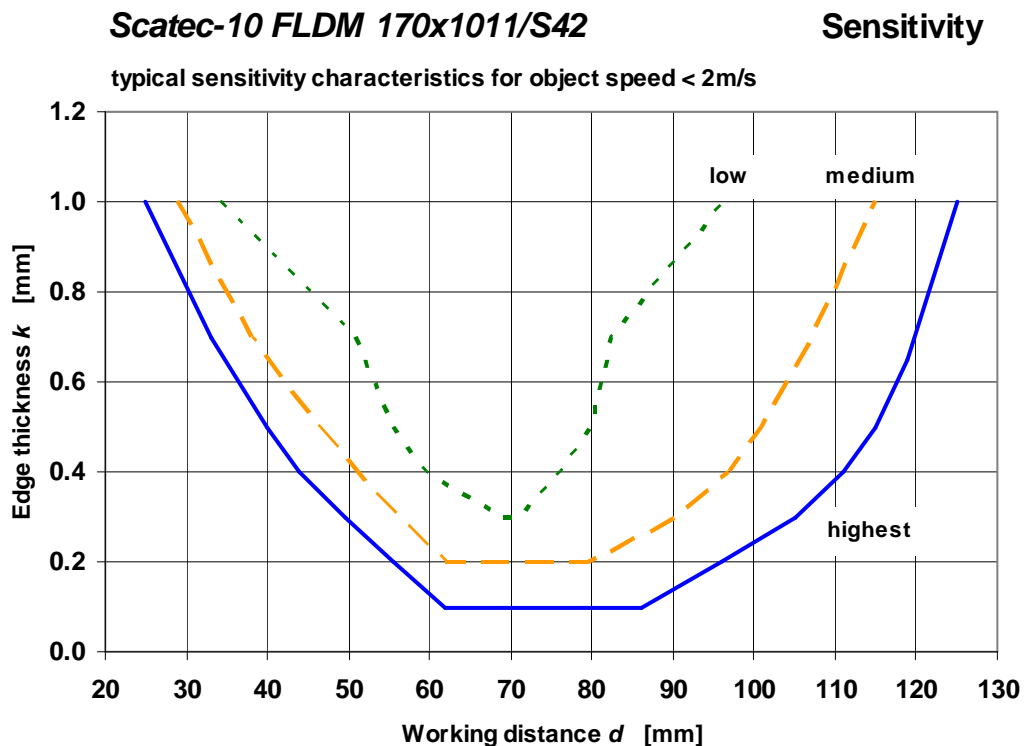

How to read the graphics: An edge with thickness  $k$  at distance  $d$  will typically be detected if the corresponding point in the graphics is above the curve representing the configured sensitivity level.  
 Test objects: cleanly trimmed flat matt paper sheet tightly lying on a flat matt white sheet of paper.

## 11.9 Default values

Operational parameters

 see section 9.1 *Flow chart for setting the operational parameters*

CAN-interface parameters

 refer to the *Scatec-15 CAN-Manual*

## 12 Accessories

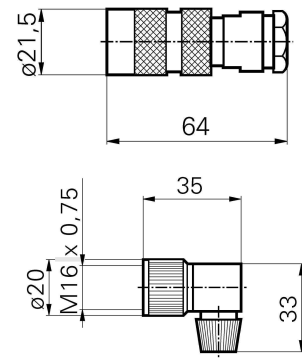
|   | <i>Article-Nr.</i> |   |
|---|--------------------|---|
| <b>Connectors</b>   |                    |   |
| Straight connector (6-pin)  | 10104236           | (enclosed)  |
| Straight connector (8-pin)  | 10153202           |   |
| Right angle connector (6-pin)   | 10153094           |   |
| Right angle connector (8-pin)   | 10153095           |   |
| (all connectors metal casing and shielded)  |                    |   |
|  |                    |   |
| <b>Cables</b>   |                    |   |
| ESG 16DP1000G   | 10156266           | Main-cable; 10m long, shielded, with straight connector (6-pin) |
| <b>Retro-reflective foil</b>  |                    |   |
| FTDF 025F025  | 10156653           | retro-reflective foil; 25mx25mm; self adhesive                  |
| <b>ScaDiag-Kits</b>   |                    |   |
| ScaDiag-Kit SCATEC-10   | 10156490           | complete set for connecting a <b>Scatec-10</b> to a PC          |
| ScaDiag-Kit SCATEC-15   | 10156491           | complete set for connecting a <b>Scatec-15</b> to a PC          |

## 13 Maintenance

The **Scatec-10 / -15** requires no maintenance apart from keeping the front windows clean. Dust or fingerprints can impair the sensor function. It is normally sufficient to wipe the windows dry with a clean (!) soft cloth. Alcohol may be used for heavy soiling.

## 14 Troubleshooting

**Whenever possible use the application software *ScaDiag* for troubleshooting!**

The software **ScaDiag** allows the user to record and to graphically display data without interfering with the running production. This is a tremendous help if there is a need to take a closer look at certain aspects of a production run. The collected data can be analyzed by the customer himself or they can be forwarded by e-mail to Baumer electric for that purpose. Troubleshooting is considerably faster if there is real data available of the production causing problems.

**15 Varying data for customized FLDM 170x10/xxxxxx**







**16 Supplements**



**Denmark**

Baumer A/S  
DK-8210 Aarhus V  
Phone +45 (0)450 392 466

**Italy**

Baumer Italia S.r.l.  
IT-20090 Assago, MI  
Phone +39 (0)245 70 60 65

**United Kingdom**

Baumer Ltd.  
GB-Watchfield, Swindon, SN6 8TZ  
Phone +44 (0)1793 783 839

**China**

Baumer (China) Co., Ltd.  
CN-201612 Shanghai  
Phone +86 (0)21 6768 7095

**Austria**

Baumer GmbH  
AT-2514 Traiskirchen  
Phone 0800 0700020

**France**

Baumer SAS  
FR-74250 Fillinges  
Phone +33 (0)450 392 466

**Sweden**

Baumer A/S  
SE-56122 Huskvarna  
Phone +46 (0)36 13 94 30

**Canada**

Baumer Inc.  
CA-Burlington, ON L7M 4B9  
Phone +1 (1)905 335-8444

**India**

Baumer India Private Limited  
IN-411038 Pune  
Phone +91 20 2528 6833/34

**Brasil**

Baumer do Brasil Ltda  
BR-04726-001 São Paulo-Capital  
Phone +55 11 56410204

**Germany**

Baumer GmbH  
DE-61169 Friedberg  
Phone +49 (0)6031 60 07 0

**Switzerland**

Baumer Electric AG  
CH-8501 Frauenfeld  
Phone +41 (0)52 728 1122

**USA**

Baumer Ltd.  
US-Southington, CT 06489  
Phone +1 (1)860 621-2121

**Singapore**

Baumer (Singapore) Pte. Ltd.  
SG-339412 Singapore  
Phone +65 6396 4131

[www.baumer.com/worldwide](http://www.baumer.com/worldwide)